

# Storage Controller PMC

## 2.5-inch SATA Disk Adapter

The 2.5 inch SATA disk adapter provides an industry standard SATA connector for mounting a 2.5 inch SATA hard drive in the space occupied by a PMC.

The HDD is positioned midway such that the PMC component envelope is not violated. Furthermore, steel rails are attached to the printed circuit board, allowing for a secure, robust installation of the hard disk drive. This is a superior mechanical approach, compared with other printed circuit board-based solutions available on the market.

This product uses the Silicon Image Sil3512 IC that supports SATA operation of a single hard drive. The Silicon Image Sil3512 controller connects the PCI bus to the one SATA link. The PCI bus can operate at 33 MHz or 66 MHz. Both 5V and 3.3V PCI bus signaling are supported.

The Silicon Image SIL3512 controller is programmed with a BIOS image stored in a 512Kx8 EEPROM.

A green status LED on the PCB conveys the activity of the hard drive.

This product is normally supplied without a hard drive, permitting purchase of drives for installation by the user. Alternatively, Technobox can quote installation and testing of drives as an additional service.

This PMC requires only 3.3V from the carrier for the internal logic. However, 3.3V, 5V and +12V are routed from the carrier to the SATA connector, and some, or all, of these voltages may be needed by the drive chosen. Check the drive data sheets for required voltages.

Contact Technobox for O/S and software support.

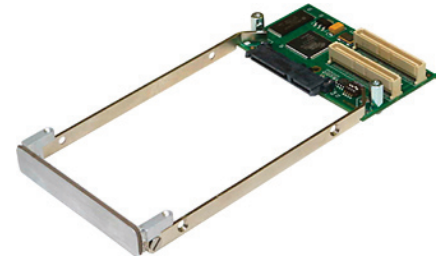

**5575**

- **Accepts 2.5" SATA HD or solid-state media**
- **Silicon Image Sil3512 controller**
- **Standard mounting**
- **Media optional**
- **RoHS-compliant, Lead-free**

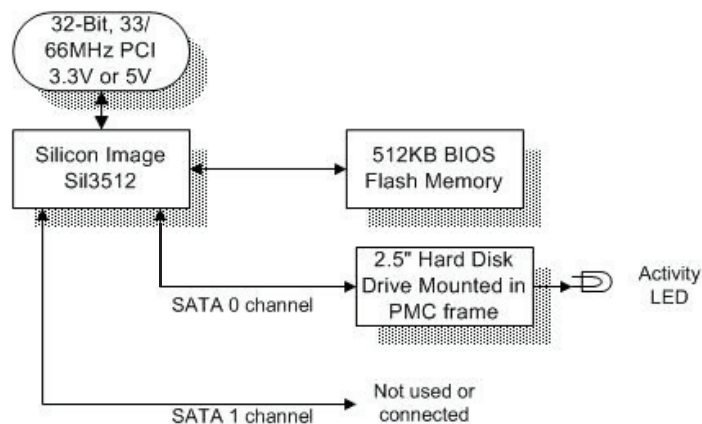

**Technobox**

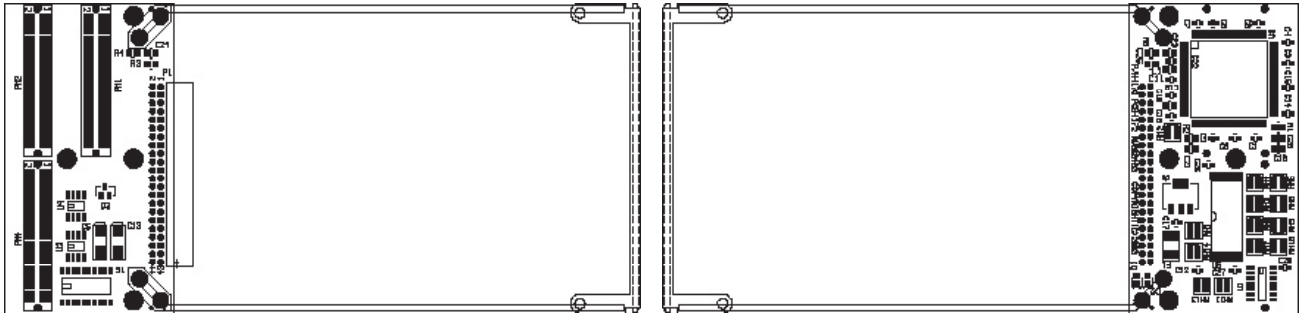

### Specifications

Temperature (Operating): 0 to +55 degrees C  
Temperature (Storage): -40 to +85 degrees C  
Altitude: Not Specified or Characterized Typical similar equipment is at 15,000 ft.  
Humidity (Operating/Storage): 5% to 90% non-condensing  
Vibration: Not specified or Characterized  
Shock: Not specified or Characterized  
MTBF: Available on request  
Weight: 45 grams without drive  
Voltages Required: 3V PMC, 3V, 5V and +12V as required by drive mounted  
PCI Signaling: 3V, 5V, 33/66 MHz, 32/64bit

### Ordering Information

5575: 2.5-inch SATA disk adapter (without media)

