

# XMC Carrier / Adapter

## XMC to PCI Express Adapter with Metering Function

The Metering XMC to PCI Express Adapter is a development/diagnostics tool that permits the testing of an XMC card in a PCI express slot (1X, 4X, 8X or 16X). It also can be used to measure current and voltages and the PCI Express bus.

Due to the vertical orientation of the mounted XMC, a user has ready access to both sides of the card. All signals on the XMC P16 connector are accessible via two 64-pin headers. PCI express lanes on the P15 XMC connector are routed to the PCI express edge finger connector. Signals reserved for future use (RFU) from P15 are available on one of the user connectors.

The adapter provides a switch to power the XMC card on and off. However, the PCI express signals are not switched to preserve signal integrity.

A convenient digital metering function measures power supply voltages (+3.3V, VPWR, +12V, -12V) and current draw of the XMC. The meter can also be used as a frequency counter that measures PCI express bus

clock frequency. Users can select the metering mode using two push-button switches. Metering modes include Real-Time display, Minimum and Maximum value capture, Range (Min-Max) display and averaging over a selectable number of samples. LEDs display the selected meter mode.

The adapter provides +12V or +5V for VPWR to the XMC card and are jumper selectable. Several activity LEDs give an indication of key XMC signals and voltages.

The MVMRO and ROOT0 output signals to the XMC card are supported on this board by DIP switch settings. MVMRO is the write protection signal for the I2C eeprom on the XMC card. ROOT0 allows the XMC card to function as a PCI express root complex and assign base addresses to the other boards in the system.

The I2C EEPROM base address GA[2..0] outputs to the XMC are set with a dip switch.

JTAG signals from the XMC bus and the PCI express bus are brought out



5277

- Adapts an XMC to a PCIe Slot
- Supports up to 8 PCIe Lanes
- Permits Access to P16 Signals, I2C, and JTAG
- Metering Function Provides Multiple Modes to Monitor and Measure XMC Voltage and Current plus PCIe Bus Frequency
- Additional LEDs Show Status of Key XMC Signals and Voltages
- RoHS 6/6 Compliant

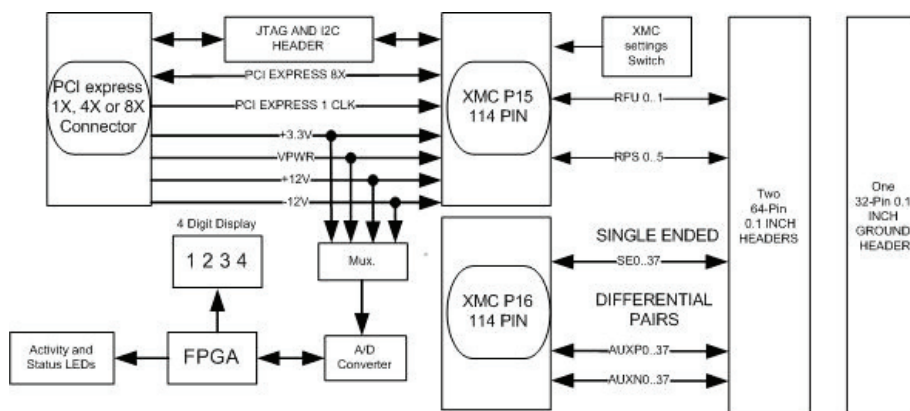

**Technobox**

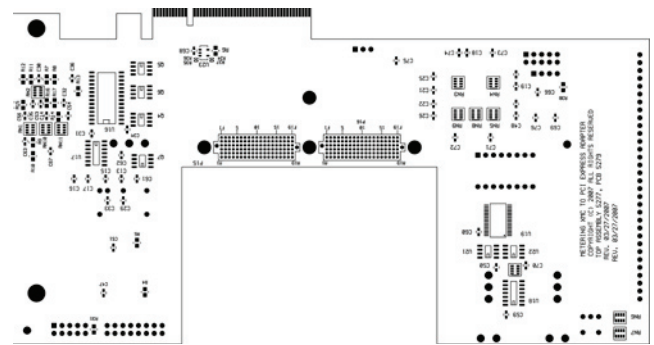
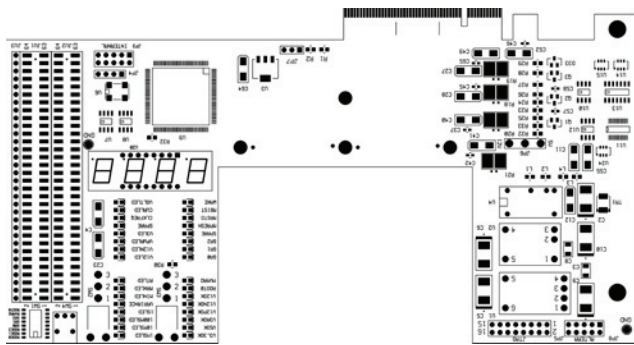

to headers for access. The I2C connections are also available.

The +12V, 3Vaux and +3.3V for the XMC bus are provided by the PCI express bus, while the -12 and +5V is generated by a DC-DC converters from the +12V supply.

This board has been carefully designed to minimize signal lengths

on the 2.5GHz PCI Express bus. Impedance-controlled signal layers and power planes are employed to minimize transmission line effects.

A high quality 2.5 mm thick machined aluminum panel, with a 0.5 mm chamfered edge, is provided on the PCI board bracket. This mimics the mechanics of a XMC installed on a VMEbus board or other host environ-

ments and allows the XMC bezel to be firmly positioned on the board.

This board requires no software support since the PCI express bus is a passive edge finger to XMC P15 connection.

### Specifications

Temperature (Operating): 0 to +55 degrees C  
 Temperature (Storage): -40 to +85 degrees C  
 Altitude: Not Specified or Characterized. Typical similar equipment is at 15,000 ft.  
 Humidity (Operating/Storage): 5% to 90% non-condensing  
 Vibration: Not specified or Characterized  
 Shock: Not specified or Characterized  
 MTBF: Available on request  
 Weight: 110 grams  
 Power: TBD  
 Voltages Required: +12V,+3.3V. Tol: +/-5%  
 Size: 4.376" x 8.1 maximum envelope

### Ordering Information

5277: XMC-to-PCI Express Adapter with Metering Function 8X  
 5328: XMC-to-PCI Express Adapter with Metering Function 4X  
 5329: XMC-to-PCI Express Adapter with Metering Function 1X

