

# PMC Carrier/Adapter

## Metering PMC-X to PCI-X Adapter with PIM Support

The Metering PMC-X to PCI-X adapter is a development that can be used for debugging and/or demonstrating the performance of a PMC card in a standard PCI slot.

The adapter supports 64-bit PCI bus through the use of JN1, JN2, and JN3 connectors per the IEEE 1386.1 specification. Both standard PCI signaling (32/64bit, 33/66 MHz) and PCI-X signaling (32/64bit, 66/100/133 MHz) are supported.

A PMC I/O Card (PIM - VITA 36) can be attached to the card via headers JN5 and JN6. The PIM signals are connected to the PMC site JN4 connector in a one-to-one signal fashion as customarily done for PIM applications.

Both the PMC and PIM under test are vertically oriented, exposing the bulk of the component areas for probing access.

The rear I/O connections for the PMC and PIM sites also go to the

“a” and “c” rows of a 96-pin DIN connector (JV1). Wiring follows the recommended practice of the IEEE 1386 specification.

The PCI bus is available for selective probing with an oscilloscope or logic analyzer via 0.1-inch centered 0.025-inch square post headers immediately adjacent to the PCI edge finger.

This board has been carefully designed to minimize signal lengths on the PCI signals. The PMC connectors are centered and placed immediately adjacent to the PCI edge finger, and are located on the opposite side of the printed circuit board to avoid crisscrossing signal runs. Four impedance-controlled signal layers and four power planes (2xGND, 3.3V, and 5V) are employed to minimize transmission line effects.

Unique to this board is a convenient digital LED metering function that separately measures power supply voltages (+3.3V, +5V, +12V, -12V) and current

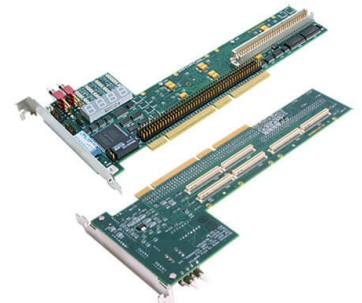

**5819**

- **PMC-X to PCI-X Adapter w/ Bus Metering Functions**
- **Multiple Metering Functions w/ LED Readout**
- **Support PCI (33/66 MHz) and PCI-X (66/100/133 MHz)**
- **Accommodates Both PMCs and PIMS**
- **Optimized Design to Preserve Signal Quality**
- **XCAP and M66EN Signals Support**
- **RoHS-compatible**
- **Lead-free**

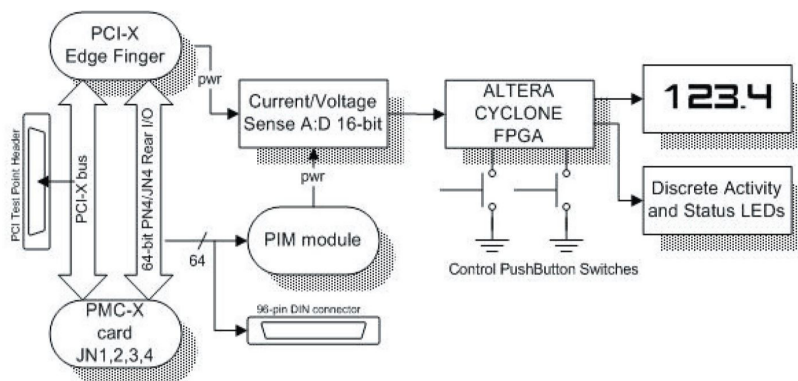

**Technobox<sup>®</sup>, inc.**

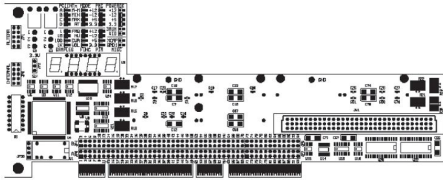

**COMPONENT PLACEMENT VIEW - SIDE #1**

draw of the PIM and PMC sites. A built-in frequency counter measures PCI bus clock frequency. Control of the meter mode and display is accomplished via two push-button switches.

LEDs display the selected meter mode and satisfactory power supply voltage levels, as well as PCI "interrupt" line (INTx) activity. Meter modes include

Real-Time display, Minimum and Maximum value capture, Range (Min-Max) display and averaging over a selectable number of samples.

The XCAP and M66EN signals are supported by this board as direct connections between the PMC site and PCI edge finger. Additionally, these connections may be reconfigured by DIP

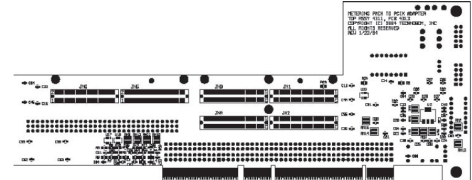

**COMPONENT PLACEMENT VIEW - SIDE #2**

switch settings to force operation at non-X or lower PCI clock frequencies.

Since this is a passive adapter, no additional software support is required for operation in a PCI slot. Software support for the PMC under test is provided by the PMC supplier.

### **SPECIFICATIONS**

**Temperature (Operating):** 0 to 70 degrees C

**Temperature (Storage):** -35 to +100 degrees C

**Altitude:** Not Specified or Characterized. Typical similar equipment is at 15,000 ft.

**Humidity (Operating/Storage):** 5% to 95% non-condensing.

**Vibration:** Not specified or characterized

**MTBF:** Available on request

**Typical Power Dissipation:** Per PMC under test

**PCI Environment:** 3.3V, 5V, PCI-X 32/64b, 33/66/100/133 MHz

### **ORDERING INFORMATION**

**5819:** Metering PMC-X-to-PCI-X Adapter w/ PIM Support

