

PMC Carrier/Adapter

Conduction-Cooled PMC (ccPMC) to PCI Express (4X) Adapter

The Technobox 6768 adapter is designed to host a Conduction Cooled PMC (VITA 20 ccPMC) in a PCI Express 4 Lane site.

The adapter orients the mezzanine card in a reverse manner such that the rear I/O from PN4 appears at the 68-pin SCSI-style connector installed on the adapter's bracket.

Furthermore, the reverse orientation of the card permits direct access to the standard front I/O (if any) within the host chassis. The differential pairing between PN4 and J1 is available in two styles - Standard and VITA 46.

A distinctive feature of the adapter is its high-capacity blower-style fan. An on-board fan controller measures the ambient temperature near the fan mounting plate and adjusts the fan speed accordingly.

A status monitor program provides temperature readings and a way to set fan parameters. Using a spe-

cial cable (P/N 6351), any dumb terminal can be attached to the adapter via its on-board serial port. Several LEDs give an indication of PCI Express lane good status and important voltages.

The XCAP and M66EN signals are supported by DIP switch settings to force operation at user selectable PCI clock frequencies.

The adapter features a PEX8114 bridge IC used in transparent mode with a PCI Express primary side and a PCI/PCI-X secondary side. The primary side of the PEX8114 bridge is a 4 lane generation 1 PCI Express interface.

The PCI/PCI-X secondary side operates at 33, 50, 66, 100 or 133 MHz in 32 or 64 bit bus width mode. Use of 5V only PCI signaling ccPMC cards is prevented by voltage keying.

This adapter is typically supported by the operating system. Software



6768

- Adapts ccPMC to PCI Express 4 Lane
- PEX8114 PCI Express Bridge
- Heat Sink & Fan Assembly for Enhanced Cooling
- PN4 I/O Presented to 68-Pin SCSI Style Connector on Mounting bracket
- 33, 66, 100, or 133 MHz; 32- or 64-bit PCI or PCI-X
- PCI signaling +3.3V only
- PMC Voltages +3.3V, +5V & -12V Generated by High-efficiency DC/DC Converters
- Anti-fretting per VITA 20
- Monitor Heat Sink & Control Fan Speed
- RoHS Compliant
- Industrial Temperature

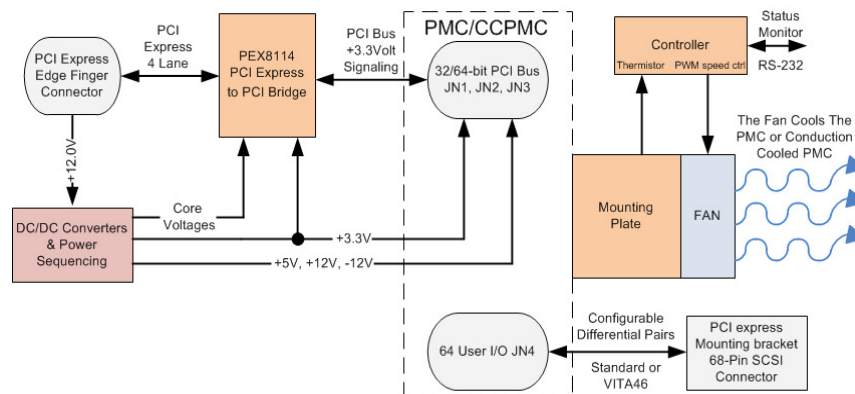

Technobox[®], inc.

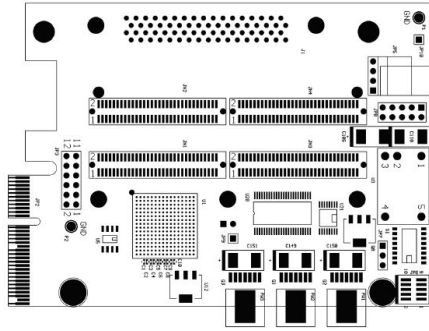

COMPONENT PLACEMENT VIEW - SIDE #1

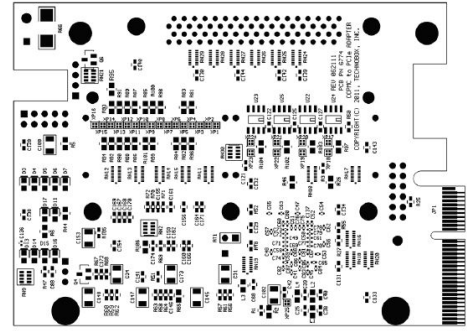

COMPONENT PLACEMENT VIEW - SIDE #2

support for the mezzanine card, however, may be necessary. Consult the card's manufacturer or an affiliated supplier for details.

The JTAG signals from the mezzanine's PCI and PCI Express con-

nectors are brought out to headers allowing users the option of connecting to the JTAG ports.

All power is supplied from the +12V connections on the PCI express edge finger connector.

For better power supply regulation the major on-board voltages (+3.3V, +5V, and -12V) are supplied from DCto- DC converters.

SPECIFICATIONS

Temperature (Operating): -40 to +85 degrees C

Temperature (Storage): -55 to +100 degrees C

Altitude: Not Specified or Characterized.

Humidity (Operating/Storage): 5% to 95% non-condensing.

Vibration: Not specified or characterized

Shock: Not specified or characterized

MTBF: Available on request

Weight: 635 grams

PCI Signaling: 3.3V only

Voltages Required PCIe: +12V +/-5%

Amperage (No PMC and no Fan): +12V 0.320 amps

PMC 5V Amperage Max: 3.0 amps at 85 deg. C

PMC 3.3V Amperage Max: 3.0 amps at 85 deg. C

PMC -12V Amperage Max: 0.75 amps at 85 deg. C

PMC +12V Amperage Max: 1.0 amps at 85 deg. C

ORDERING INFORMATION

6768: ccPMC to PCI Express Adapter – Standard differential PN4 I/O

6773: ccPMC to PCI Express Adapter – VITA 46 differential PN4 I/O

6351: Cable to interface temperature and fan control features

