

XMC Carrier/Adapter

Reverse Compact XMC to PCI Express Adapter w/ Rear I/O

The Technobox XMC to PCI Express adapter with Rear I/O support permits use of a standard VITA 42.3 air cooled XMC, or VITA 20 conduction-cooled XMC, in the smallest possible edge finger PCI Express form factor. The length of the adapter is the length of the XMC, and 10 mm mezzanine stacking height is supported. The height is a standard PCI Express board, and is not the low-profile version.

The adapter (P/N 8260) provides up to 8X lanes of connection from the XMC P15 connector to the PCI Express edge finger. Variants of the board are available to support 4X (P/N 8613) and 1X lanes (P/N 8615). PCI Express Gen 1 (2.5Gb/s), Gen 2 (5Gb/s), and Gen 3 (8Gb/s) is supported, and the adapter may be built with VITA 61 connectors for enhanced performance.

The XMC front panel is situated at the end of the adapter for applications needing I/O connectivity within the cabinet. Rear I/O from the XMC's P16 and PN4 connector is wired to a 68-pin SCSI-style connector located at the I/O bracket end of the adapter. Connectivity is limited to X24s+X8d+X12d per VITA 46.9. For PN4 connection, two differential pairing styles are supported, as implement with solder jumpers between the PN4 and 68-pin connector; please see Technobox product manual for more details.

A large hole as seen in the profile of the board enhances convection airflow which might be adequate for cooling low power XMCs. For high power XMCs, an optional P/N 8254 user-installable fan assembly is available. This is a highly reliable ball-bearing "blower" style fan (50Khr MTBF) normally used for cooling processors, has a plentiful 11 CuFT/min airflow, and does not "stall" as can be the case with pancake fans. The 4-pin fan cable can be connected to either a spare fan connector on the motherboard, or to a 4-pin header on the adapter board. An on-board microcontroller based fan controller has 5 speed settings as set by a pushbutton at the edge of the adapter, and the setting is retained in the controller's NV memory. The fan controller provides an opto-isolated malfunction "alarm" via a connector at the edge of the board that can be wired in to an available system IPMI contact sensor or other alarm mechanism if desired.

Note the height of the fan is 15 mm off the back side of the adapter, and will take up the adjacent slot. The standard board-to-board pitch for PCI Express is 20.32 mm, and it's possible some PCI Express cards in the adjacent slot might clear the fan, and this needs to be demonstrated with the customer's specific board set.

This product will accommodate either air-



8260

- **Smallest Possible Form Factor**
- **Adapts XMC to PCI Express: 1x, 4x, and 8x lanes**
- **VITA 42 Connector Standard**
- **VITA 61 Connector Standard**
- **Powerful Blower fan option – 11 CuFT/min**
- **On-board FAN Controller**
- **Fan Tach Alarm & Speed Setting**
- **VPWR Either 12V or 5V per Jumper/Disk Connector**
- **Generates -12V rail to XMC**
- **Provides +3.3 & +12V from PCIe Edge Finger**
- **Status LEDs**
- **Power LEDs**
- **DIP switch for Geographical address, etc.**
- **X24s+X8d+X12d from P16 to 68-pin SCSI style connector**
- **PN4 connection to 68-pin SCSI in two differential pairing styles**
- **Supports Air-cooled or Conduction-cooled XMCs**
- **Industrial Temperature**
- **RoHS Compliant**

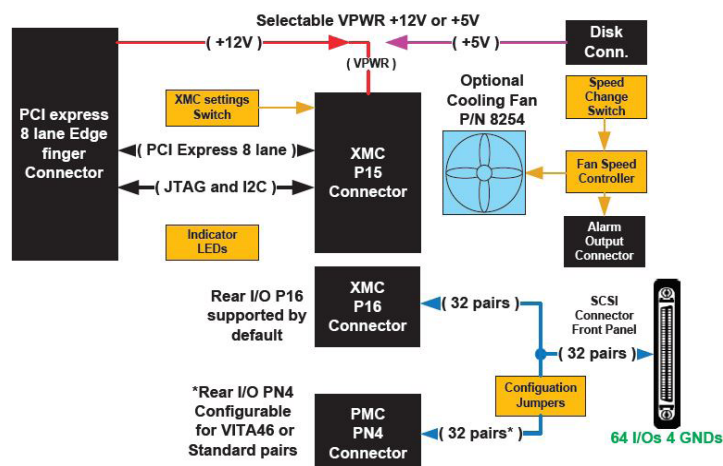

Technobox[®], inc.

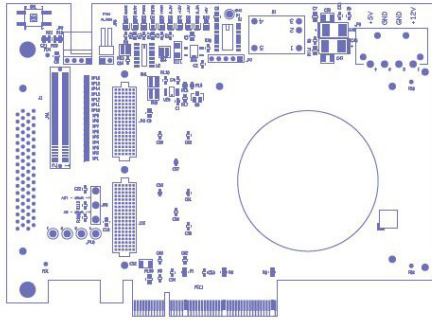

COMPONENT PLACEMENT VIEW - SIDE #1

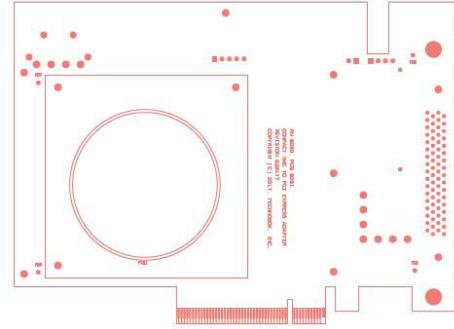

COMPONENT PLACEMENT VIEW - SIDE #2

cooled (VITA 42) or conduction cooled (VITA 20) XMCs. Although the conduction cooling bars are not present, the forced air cooling over a conduction cooled board should be adequate in most cases when using the fan option.

The installed XMC is provided with +12V and +3.3V directly from the PCI Express edge fingers. -12V is provided by an on-board POLA module. XMC "VPWR" is set to either 12V or 5V using a jumper on the adapter. Power for the 12V position comes from the

edge finger, while 5V is provide by a four-pin Molex disk supply connector readily available with most PC power supplies. Note that a properly designed XMC should work with either voltage, so connection to a disk power connector should not be required.

DIP switches provide various configurations for the XMC, such as geographical address. LEDs provide status, such as available power and XMC status signals (WAKE, PRESENT, etc). The adapter is built with Industrial Temperature range (-40 to +85

Deg C) parts, and is RoHS compliant. The optional fan is specified at -10 to +65 Deg C.

The standard P/N's 8615, 8613, and 8260 have JN4 and J16 to mate with PN4 and P16 on the XMC. The solder jumpers to provide connection from PN4 to the 68-pin SCSI style connector are not installed. Technobox will assign unique orderable part numbers to accommodate the differential pairing style, VITA 61 connector use, and other customer application specific requirements as needed.

SPECIFICATIONS

Temperature (Operating): -40 to +85 degrees C

Temperature (Storage): -55 to +100 degrees C

Altitude: Not Specified or Characterized. Typical similar equipment is at 15,000 ft.

Humidity (Operating/Storage): 5% to 90% non-condensing.

Vibration: Not specified or characterized

Shock: Not specified or characterized

MTBF: Available on request

Weight: 84 grams, 160 grams with fan assembly

Power: Negligible since this is a passive adapter

Voltages Required: +12V,+3.3V. Tol: +/-5%

Power: 0.96W@+5V, 0.22W@-12V, 0.012W@+12V

Size: 4.377" x 6.00" , 0.062" thick +/- 10%

Amperage XMC: 8 amps VPWR +12V or +5V , 4 amps +3.3V, 1 amps +12V, 1 amps -12V

*Operating with the fan assembly is limited to -10 to +85 degrees C, unplug the fan for lower temperatures.

ORDERING INFORMATION

8260: Short Length, Reverse Compact XMC to PCI Express Adapter with Rear I/O - 8X

8613: Short Length, Reverse Compact XMC to PCI Express Adapter with Rear I/O - 4X

8615: Short Length, Reverse Compact XMC to PCI Express Adapter with Rear I/O - 1X

8254: Optional fan assembly; ball-bearing blower style (11 cfm) w/ mounting hardware

