

Multifunction RS422/RS485 Digital I/O PMC

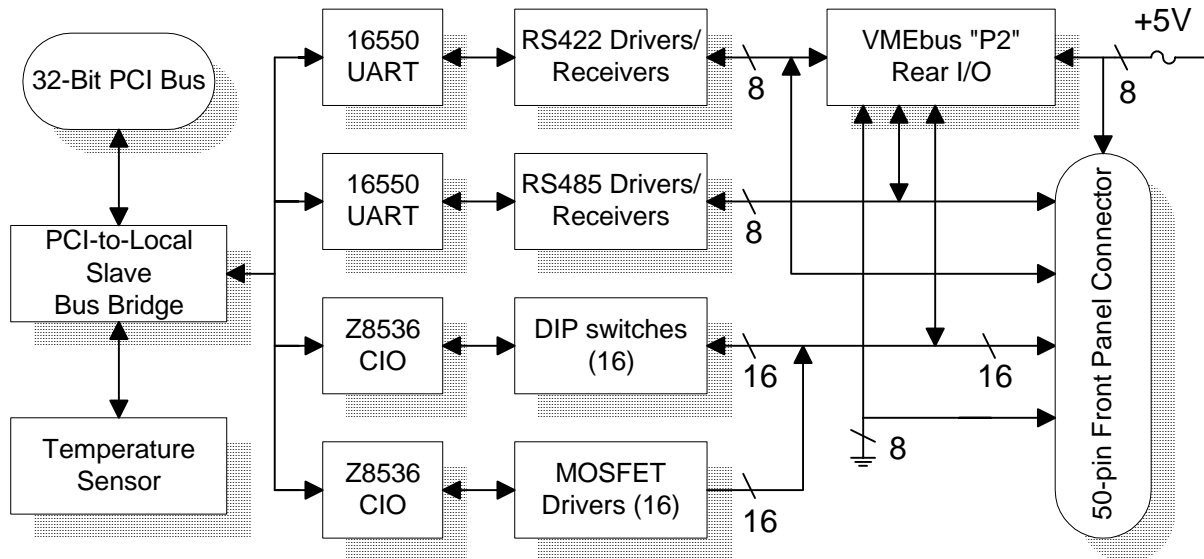

The Multifunction RS422/RS485/Digital I/O board provides a collection of various interfaces on a single-wide PMC module.

Functions performed by this board are:

- One 16550 based UART with RS422 interface.
- One 16550 based UART with RS485 interface.
- 16 bit-oriented Digital I/O as driven by Z8536.
- Temperature Sensor.

The two 16550 UARTs on the board provide asynchronous communication at bit rates to 115Kbaud. The 16550's are mapped into host processor space so that standard drivers can be used with the board.

Each UART interface provides TXD, RXD, CTS, and RTS control signals. In one case, an RS422 interface, with 150 ohm termination, is implemented. In the other case, RS485 (mult-drop RS422) is used, with the RTS controlling data direction, as is customarily done with RS485 interfaces.

The board also provides a total of 16 general purpose digital I/O lines as driven by one Zilog 8536 Counter/Timer/Parallel I/O chip. Four Z8536 Counter/Timer channels are available on these pins, each providing count input, count output, gate and trigger functions. The digital I/O may be used as bit-oriented inputs or outputs.

The digital I/O lines also feature low-resistance open-drain MOSFET drivers with ON resistances less than 0.2 Ohms, with a 20 Volt maximum in the OFF state. These are used for Lamp, LED, and relay drivers. The gate of the MOSFET is driven by a second Z8635, and each I/O line can be switch selected for drive by either the MOSFET or the first Z8635.

Connection to the board is accomplished via a 50-pin "SCSI" style connector out the front panel. These signals are also routed to the rear I/O connector (PN4) on the PMC, which may be routed out the backplane of a cPCI or VMEbus system for host processors which provide rear I/O connectivity.

Ground and a fuse protected +5V power is provided at the connectors for powering user interfaces. These power lines are alternated with the digital I/O signals in order to reduce cable crosstalk.

The PCI bus interface uses a slave-only PLX 9050 part, and the 16550 UARTS and Z8635's are mapped into host processor I/O space via the PCI configuration "BAR" registers.

A final feature of the board is a temperature sensor for measuring, in 0.5 degree C increments, temperature in the proximity of the PMC module.

"C" source code is provided with the product, and may be compiled into the user's application or O/S drivers.

Multifunction RS422/RS485/Digital I/O PMC

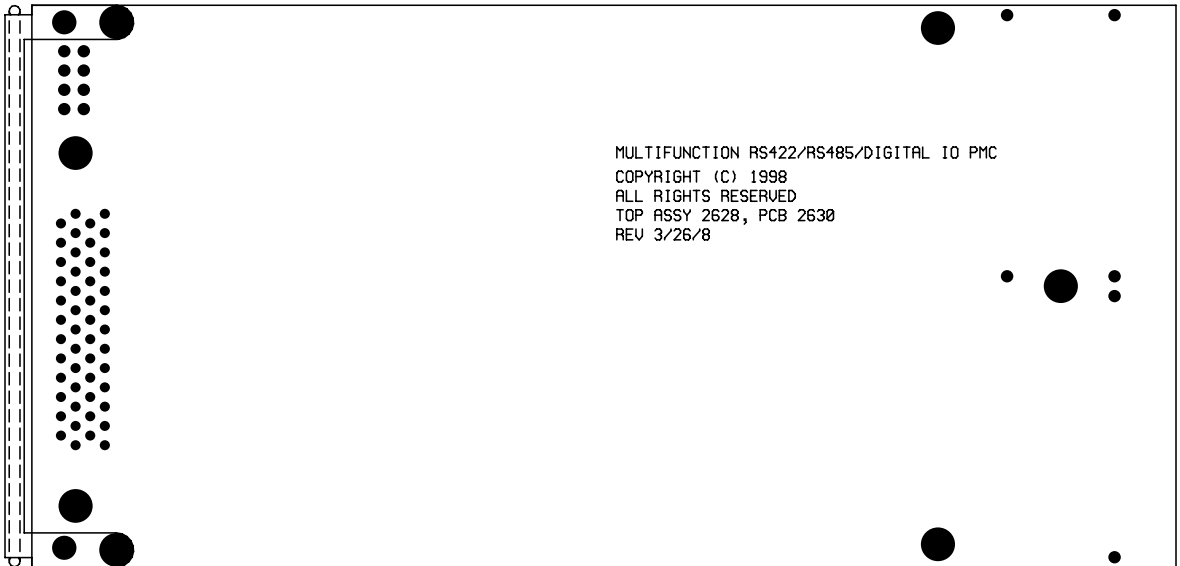
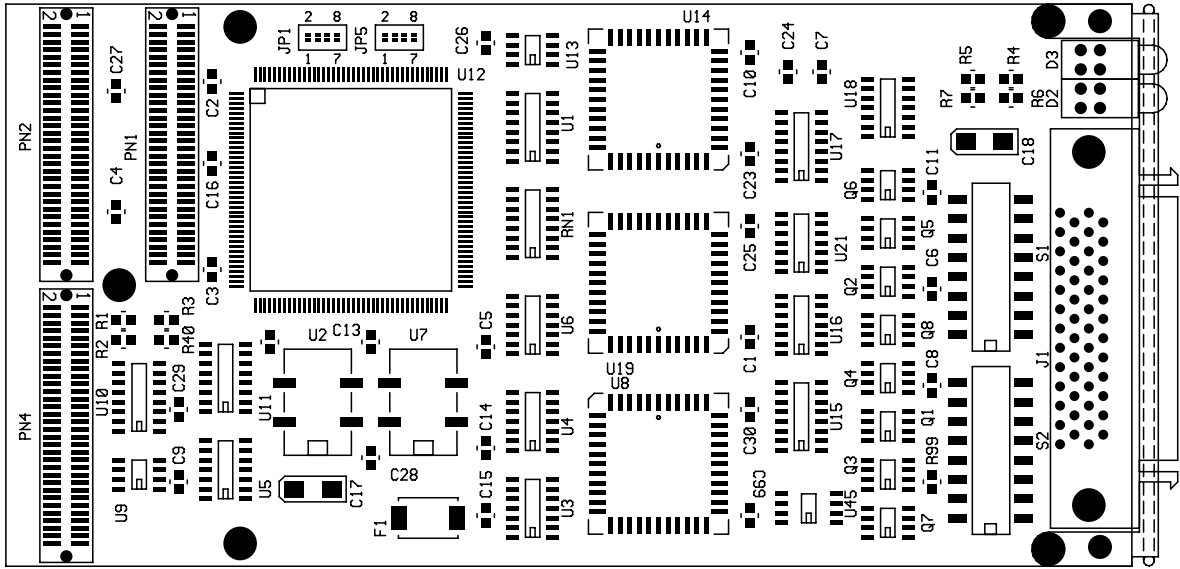

Product Summary

Technobox Part Number:	2628
Typical Power Dissipation:	TBD watts
Power Supplies Required:	+5
PCI Signaling Environment:	5 Volt