

# Asynchronous I/O XMC

## 4-port RS232/RS422/RS485 Async Communications Adapter XMC

The Technobox 4-port Async Communications Adapter XMC is a cost-effective solution for providing additional RS232/RS422/RS485 based async serial ports for a host processor. It is the next generation version of Technobox's P/N 4960/2012 PMC product, which has been in continuous production since the 1990's.

A high degree of compatibility for this XMC is maintained with the prior 4960/2012. First, the same genuine 16C554 chip is used for the UART functionality, guaranteeing correct async operation when compared to competitive FPGA based approaches. Second, the port configuration strategy, using jumpers installed by Technobox upon customer order, is identical. Third, the UARTs are mapped into PCI Express I/O space, consistent with Personal Computer COM port practice; reprogramming a PLD can map ports into Memory Space. Finally, the same Micro D9 connectors, as well as PN4 Rear I/O, is retained in this XMC.

Access from the 1-lane PCI Express interface is accomplished through a PCI Express to PCI-bridge. The local parallel PCI bus is then adapted to the 16554 quad UART interface using a PLD on

the board. Thus, to the user, it will appear that the COM ports are located behind a PCI-to-PCI bridge.

Unlike the 4960/2012, there are no mechanical interrupt switches to steer the individual UART interrupts to INTx (x = A, B, C, D) for the PCI bus. All UART interrupts are posted on the INTA line by default. However, there is a programming technique, that is also deployed on other Technobox Async adapters, to steer the interrupts via software to the desired interrupt request levels. It is believed that most 4960/2012 users have all UARTs directed to INTA, so change is unlikely

Also unlike the 4960/2012, this XMC only requires +3.3V power rail. The RS232 interface chips generate elevated voltages, which were provided by +/-12V rails in 4960/2012, using built-in switched capacitor voltage multipliers.

Each port is independently set-up by Technobox to operate at either RS232 or RS422 levels. In the RS422 case, an additional option is provided to transmit data on the receive data line in an RS485 fashion. The port configuration must be specified when ordering.

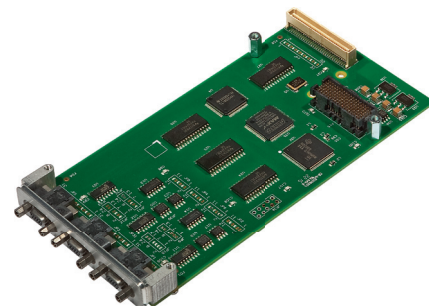

7254  
.....

- 4-port Async RS232/422/485 I/O XMC (VITA 42 or VITA 61)
- One PCI-express Gen-1 lane (2.5 Gb/s)
- Provides 4 async serial ports (16550 UARTS)
- Each port configurable as RS232, RS422, or RS485
- Micro D9 sub-miniature front panel connectors
- Software selectable PCI interrupt configuration
- Optional cable assembly supports standard DB-9 interface
- Built with I-Temp components (-40 to +85 Deg C)
- Ports accessible via PN4 rear I/O
- Only 3.3V power rail
- RoHS-compliant

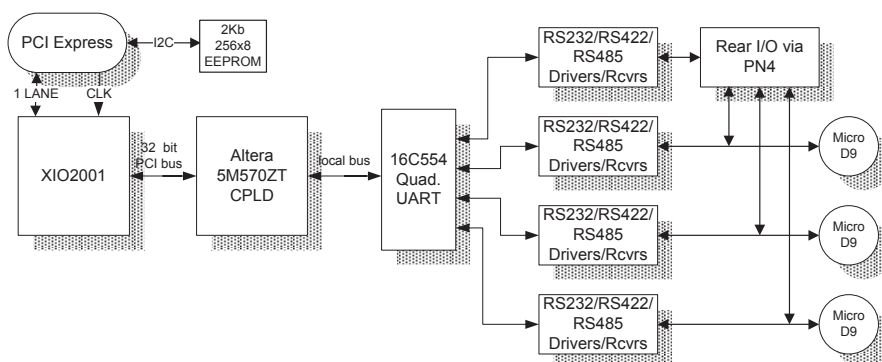

**Technobox**

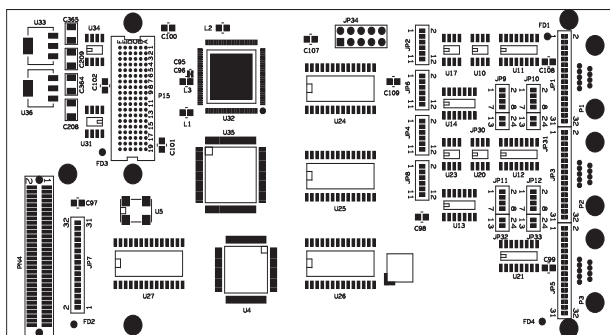

Component Placement View - Side 1

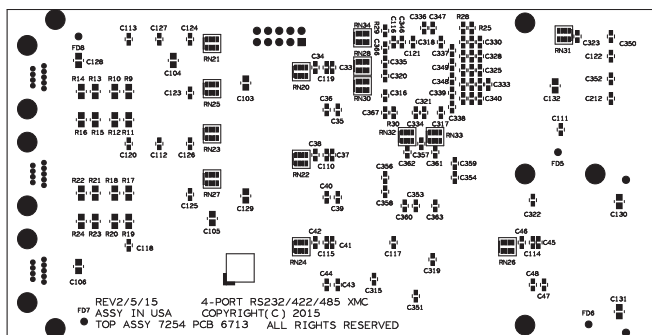

Component Placement View - Side 2

When configured for RS232 mode, a port provides the full set of data and modem control lines — RTS, CTS, TXD, RXD, DCD, DTR, DSR, and RI.

When configured for RS422 mode, a port provides TXD, RXD, CTS, and RTS, each operating at RS422 differential levels with unidirectional drive.

The RS485 mode supports both 2-wire and 4-wire RS485 connections. In 2-wire mode, a single differential RS422 driven pair carries transmit or receive data in a half-duplex fashion. For 4-wire mode, the TXD is also driven on an additional RS422 unidirectional output. Control of transmit/receive direction is accomplished

via the RTS control signal from the 16650 UART, as is customarily done for RS485 applications.

Options to terminate the differential RS422/RS485 signals with 150 ohm parallel termination are provided by the design. Please specify your termination requirements on order.

Three of the four ports are accessed via 9-pin Micro D Sub-miniature connectors on the PMC front panel. All four ports are also available out the rear I/O connector on the PMC. For example, when used with a VITA 35 compliant VME board, the ports are available on the P2 VMEbus connector for host processors which sup-

port rear I/O connectivity. The P2 pinning is defined so that an IDC terminated ribbon cable is broken out to four individual 9-pin Standard D Subminiature connectors for rear I/O connection.

Industry standard 16550 UARTS operating up to 115K baud are used in this product. The 16550 register set is accessed from the host processor using Programmed-I/O. "C" source code is provided with the board to illustrate how to set up the PCI bus bridge in order to access the UART registers. Once the registers are mapped into host I/O space, standard async communication drivers may be used to access the ports.

### Specifications

- Temperature (Operating): -40 to +85 degrees C
- Temperature (Storage): -55 to +105 degrees C
- Altitude: Not Specified or Characterized. Typical similar equipment is at 15,000 ft.
- Humidity (Operating/Storage): 5% to 95% non-condensing
- Vibration: Not specified or Characterized
- Shock: Not specified or Characterized
- MTBF: Can be calculated upon request
- Weight: 75.4 grams
- Voltages Required: +3.3V
- PCI Express: GEN-1 (2.5Gb/s)
- Power: TBD Amps on VPWR

### Ordering

- 7254: 4-port Async Comm Adapter XMC. Front and Rear I/O. Ports configured for RS232, RS422 or RS485 operation in any mix. Standard baud rates to 115Kbaud. 16550 UART equivalent via PLX OXPICe954 chip. MicroD9 connectors on Front Panel.



Copyright © Technobox 2015 DS7254-B50806  
All other brands or names are property of their respective holders

Technobox, Inc.  
154 Cooper Road  
Suite 901  
West Berlin, NJ 08091  
Tel: 856-809-2306 • Fax: 856-809-2601  
www.technobox.com info@technobox.com