

XMC Carrier/Adapter

“Tech Refresh” 8-Lane XMC-to-PCI Express Adapter

Technobox P/N 10322 is a passive 8 lane PCI express to XMC carrier which permits the use of XMC cards in PCI express 8 lane or 16 lane motherboard edge card slots.

A variant P/N 10433 provides a 4 lane PCI express edge card interface and P/N 10434 provides a 1 lane PCI express edge card interface.

P/N 10322 and variants use the VITA42 XMC connector, but variants which use the VITA61 XMC connector are also available.

Technobox P/N 10322 also provides user access to all the signals on the XMC P16 connectors via 2 64 pin headers JU1 and JU2. The P16 differential pairs are routed to JU1/JU2 so that twisted pair ribbon cables can be used.

These boards are fit, form and function compatible with their

P/N 4821 family equivalents, which may not be able to be sourced do to component obsolescence.

General purpose I/O on PN4 is not supported, if PN4 I/O signals are required consider the Technobox P/N 5933 family of products.

Several activity LEDs give an indication of key XMC and PCI express signals and voltages.

The signals unique to the XMC standard such as GA[2..0], MVMRO and ROOT0 are supported by DIP switch settings.

The JTAG and I2C signals from the XMC connector and the PCI express edge card connector are brought out to headers for user access.

A high quality 2.5 mm thick machined aluminum panel, with a 0.5 mm chamfered edge, is pro-



10322

- Adapts an XMC Card to PCIe Slot
- Supports up to 8 PCI Express Lanes
- Status LEDs Show XMC & PCIe Status & Activity
- XMC Signals from P16 are Accessible via Two 64-pin Headers
- Headers Provide Access to JTAG & I2C signals
- Provides 12 Volts Only VPWR
- Also Offered w/ VITA 61 Connectors See P/N 9296
- Optional Fan Assembly to Augment Cooling
- Fit, Form & Function Replacements for P/N 4821 Family of Products
- RoHS-compatible
- Lead-free

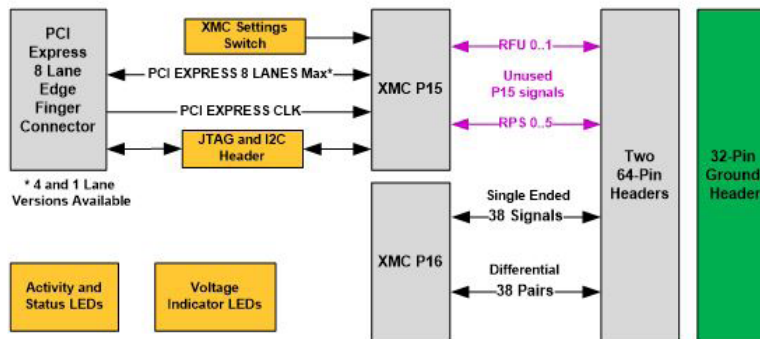

Technobox[®], inc.

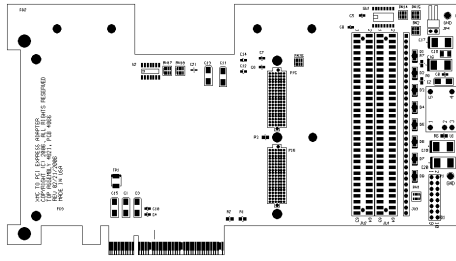

COMPONENT PLACEMENT VIEW - SIDE #1

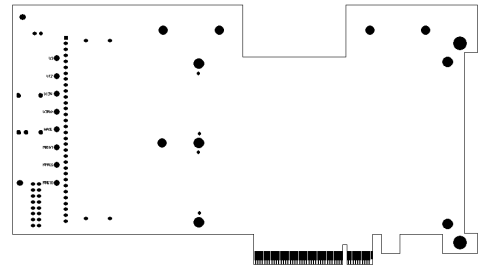

COMPONENT PLACEMENT VIEW - SIDE #2

vided on the PCI board bracket. This mimics the mechanics of an XMC installed on a VME board or other host environments and allows the XMC bezel to be firmly positioned on the board.

An optional fan assembly (P/N

4936) is available that fits over one or two carriers and provides substantial forced-air cooling of high-power XMC modules.

Note that VPWR on the Technobox P/N 10322 family of products is fixed at +12V, if +5V

VPWR is a requirement consider the Technobox P/N5933 family of products.

SPECIFICATIONS

Temperature (Operating): -40 to +85 degrees C

Temperature (Storage): -55 to +100 degrees C

Altitude: Not Specified or Characterized. Typical similar equipment is at 15,000 ft.

Humidity (Operating/Storage): 5% to 95% non-condensing.

Vibration: Not specified or characterized

MTBF: Available on request

Typical Power Dissipation: TBD

Power Supplies Required: +3.3V, +12V

PCI Express Environment: +3.3V, +12V

ORDERING INFORMATION

10322: Tech Refresh 8X PCI express XMC carrier, P16 I/O

10433: Tech Refresh 4X PCI express XMC carrier, P16 I/O

10434: Tech Refresh 1X PCI express XMC carrier, P16 I/O

4936: Optional Fan Assembly

